

**FERGUSON
DRILL PLANTER
D-PO-A-20
and
FERTILIZER ATTACHMENT
A-RO-B-60**

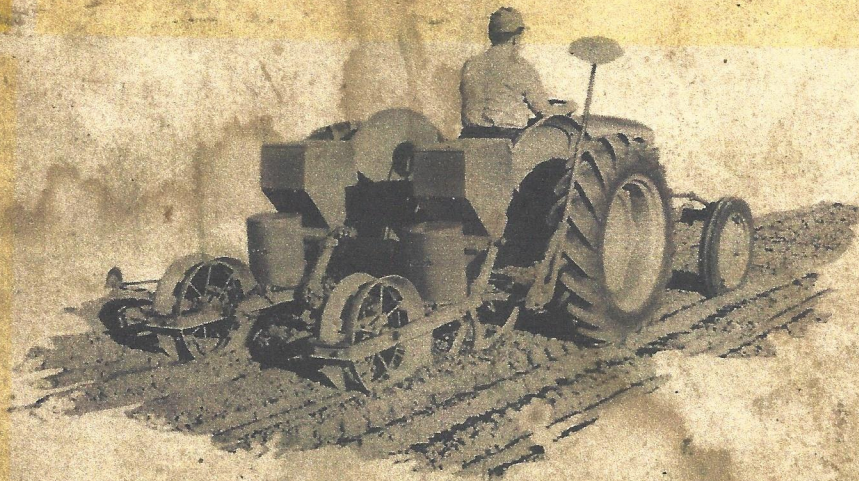

**OPERATING
and ASSEMBLY
INSTRUCTIONS**



HARRY FERGUSON, INC.

DETROIT, MICH.

INDEX

	Page
Introduction	1
Lubrication	3
Operating Instructions and Suggestions	
1. Pre-Operating Instructions	3
2. Field Operations	3
3. Adjustments	
a. Row Spacing	4
b. Disc Markers	5
c. Marker Chains	5
d. Depth of Planting	6
e. Drive Chain	6
f. Press Wheel Scrapers	6
g. Seating of Hopper	6
h. Tractor Wheel Spacing	7
i. Seed Spacing	7
Seed Spacing Chart	8
Seed Plates and False Plates	8
Hopper Operation	9
Drive Chains	10
Press Wheel and Hub	10
Assembly Instructions	10
Accessories	
1. Fertilizer Attachment	
a. Lubrication	15
b. Adjustment	15
c. Hopper	17
d. Maintenance	17
e. Assembly Instructions	19
2. Press Wheel Band Attachment	21
Seed Plate and False Plate Chart	21

HARRY FERGUSON, INC. • DETROIT, MICHIGAN.

All specifications are subject to change without notice

Owner's Name _____

Your Ferguson Dealer _____

Dealer Address _____ Phone _____

Planter Serial No. _____

Located on Name Plate as Shown on Opposite Page

FERGUSON DRILL PLANTER D-PO-A-20

Modern farming practices require faster methods of planting crops to complete the operation while the seedbed and weather conditions are favorable. Proper timing of the planting operation will result in maximum germination of the seed, better weed control, uniformity of growth and maximum yield.

To meet this demand for high-speed farming, HARRY FERGUSON, Inc. has developed a flat-land drill planter. This new Ferguson D-PO-A-20 Drill Planter is a two-row, flat-land, edge-drop implement which is capable of accurately planting seed up to seven miles per hour. While operating at this speed, it is possible to plant four and one-half acres per hour with a row spacing of 42 inches. While it is primarily used for planting corn, it is also designed to plant most types of beans, peas and sorghum grain. A wide selection of seed plates and false plates are available to handle the various requirements.

The Ferguson Drill Planter is designed as a close-coupled implement, which is attached to the tractor by the Ferguson three-point linkage. The combination of the close coupling of the planter to the tractor and the tractor hydraulic lift allows a shorter turning space at the end of the rows. It also provides a convenient method of transporting the planter to and from the field.

The rigidly-constructed planter frame connects the extra-wide press wheels closely to the runner openers to provide accurate planting depth and seed placement.

The fertilizer attachment is of the positive-feed type, which is easily adjusted for output by the proper selection of sprockets. The fertilizer can be deposited in the drill row, or on either side and at various selected depths.

Included in this manual is information concerning lubrication, operation, adjustments, service and maintenance, assembly instructions and numerous illustrations of the Ferguson Drill Planter.

Read, study and follow these instructions to get longer life, maximum performance and the utmost satisfaction from this implement.

Only GENUINE FERGUSON REPAIR PARTS should be used on your FERGUSON DRILL PLANTER. These parts are designed and built to fit correctly and give maximum service. These may be purchased only from your AUTHORIZED FERGUSON DEALER.

ALL FERGUSON equipment is identified by a FERGUSON name plate. If this name plate is not attached, it is not FERGUSON equipment. Check for the name plate before purchasing the equipment. This name plate, as shown below, also supplies the serial number, which should be noted when ordering parts.



FERGUSON D-PO-A-20 DRILL PLANTER

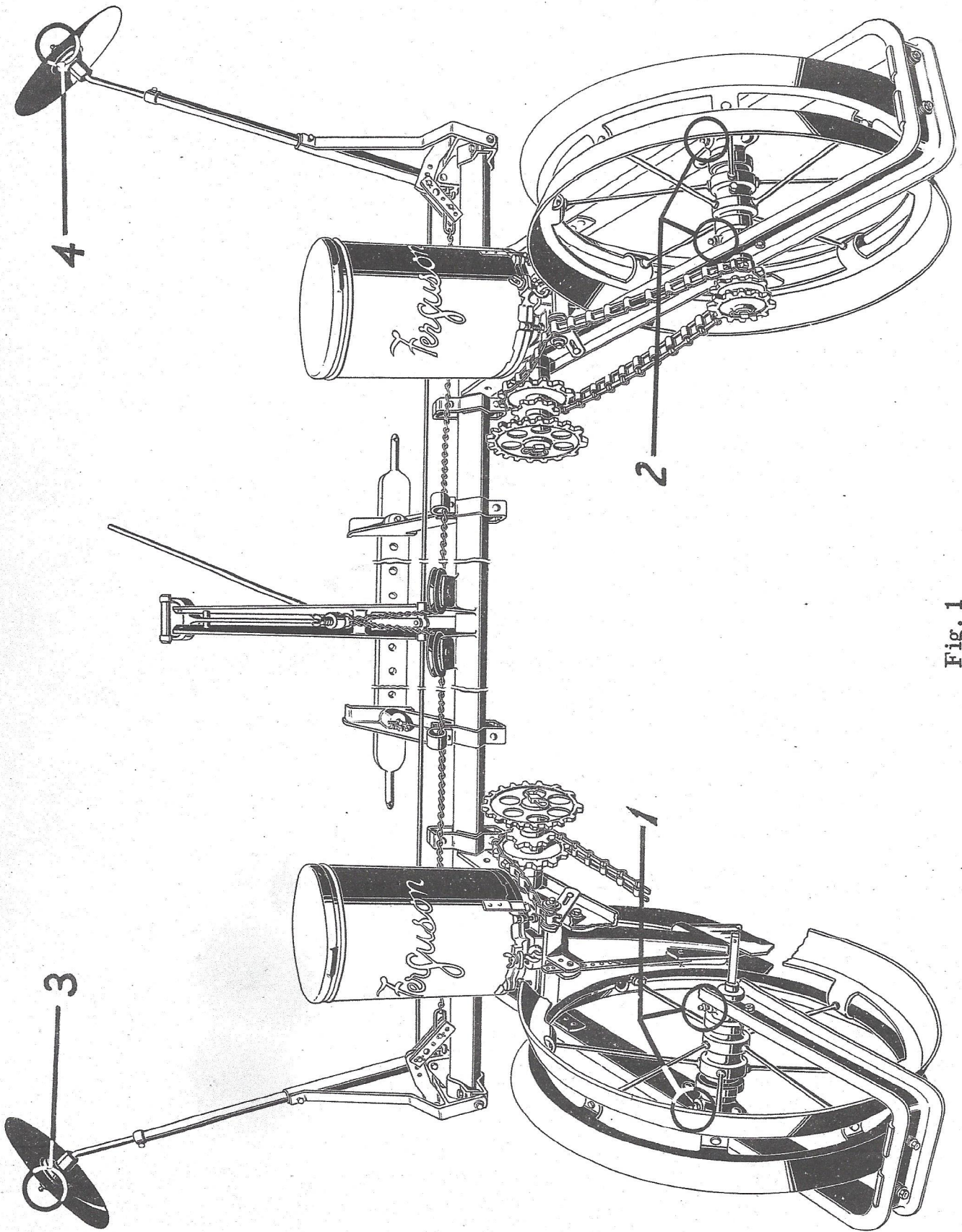

Fig. 1

LUBRICATION

There are only six pressure grease fittings located on the planter which will require a chassis lubricant. The four press wheel fittings 1 and 2, Fig. 1, and the marker discs 3 and 4, Fig. 1, require lubrication every four hours.

The marker chain pulleys and drive chain idlers will require a few drops of oil every four hours.

The hopper shaft bushing will require an application of oil at the end of each planting season.

OPERATING INSTRUCTIONS AND SUGGESTIONS

The Drill Planter, as it is delivered by your Ferguson Dealer, will come as a completely assembled unit. Included with the planter will be three sets of seed plates and one false plate. These were selected to meet the average requirements throughout the country. Your dealer should be consulted regarding the selection of additional plates and the general operation of the planter.

A. PRE-OPERATING INSTRUCTIONS

1. Check all nuts and bolts for tightness.
2. Lubricate according to instructions outlined in the Lubrication Section.
3. Select correct seed plates and false plates. (Page 8)
4. Examine seed plate cutoff and knock-out roller for free action. (Page 9)

5. Adjust hopper seat bolts for proper gear mesh on drive pinion. (Page 7)
6. Set tractor wheel spacing. (Page 7)
7. Adjust planter unit for desired row spacings. (Page 4)
8. Position disc markers. (Page 5)
9. Determine required seed spacing and select chain sprockets (Page 8), and pinion position (Page 6).
10. Determine required planting depth and set runner position. (Page 6)

B. FIELD OPERATIONS AND ADJUSTMENTS

1. Field Operations

Listed below are several operational hints and suggestions which will aid the operator in the field. Follow these suggestions for better performance from your planter.

(a) The planter is held in the level position by a lock pin M, Fig. 2, inserted into the drawbar. Upon lowering the planter to the ground for planting operation, this pin must be withdrawn from the drawbar to allow the planter full flexibility and freedom to follow the contour of the land. This pin is plated and left unpainted as a constant reminder not to operate the planter when it is inserted in the drawbar.

(b) In some cases, it may be found necessary, especially in hilly, rough terrain, to use the A-TO-59 Stabilizer Kit. This can be obtained from your Ferguson Dealer.

(c) Do not back tractor while planter is in lowered position. Raise and lower planter while tractor is moving forward to prevent the runner from clogging, especially in damp soil conditions.

(d) The markers automatically raise when the planter is raised. To lower, move the latch control rod to the right to release the R.H. marker, and to the left to release the L.H. marker. Do not attempt to lower markers with planter in raised position.

(e) The hydraulic control lever should be kept in the full-lowered position dur-

ing planting operation. This allows the planter weight to be carried by the press wheels, permitting more traction and better soil packing around the seed. This also permits the planter to fully "float" with the contour of the ground.

2. Adjustments

Although the adjustments of the planter are discussed in detail, it must be remembered that these adjustments are close approximations and must be actually tested in the field to obtain satisfactory operation.

(a) Row Spacing

Row spacings ranging from 22" to 52" may be obtained when the planter is operated without the fertilizer attachment. With the fertilizer attachment mounted, it is possible to plant rows spaced from 28" to 52". With the markers removed, row spacing may be increased to 56"

The square bar of the main frame has five notches, one inch apart, located midway between the center and each end. A notch on the planter frame attaching brackets may be aligned with any of these five notches to provide quick row spacings of 36", 38", 40", 42" and 44". For other row

FERGUSON D-PO-A-20 DRILL PLANTER

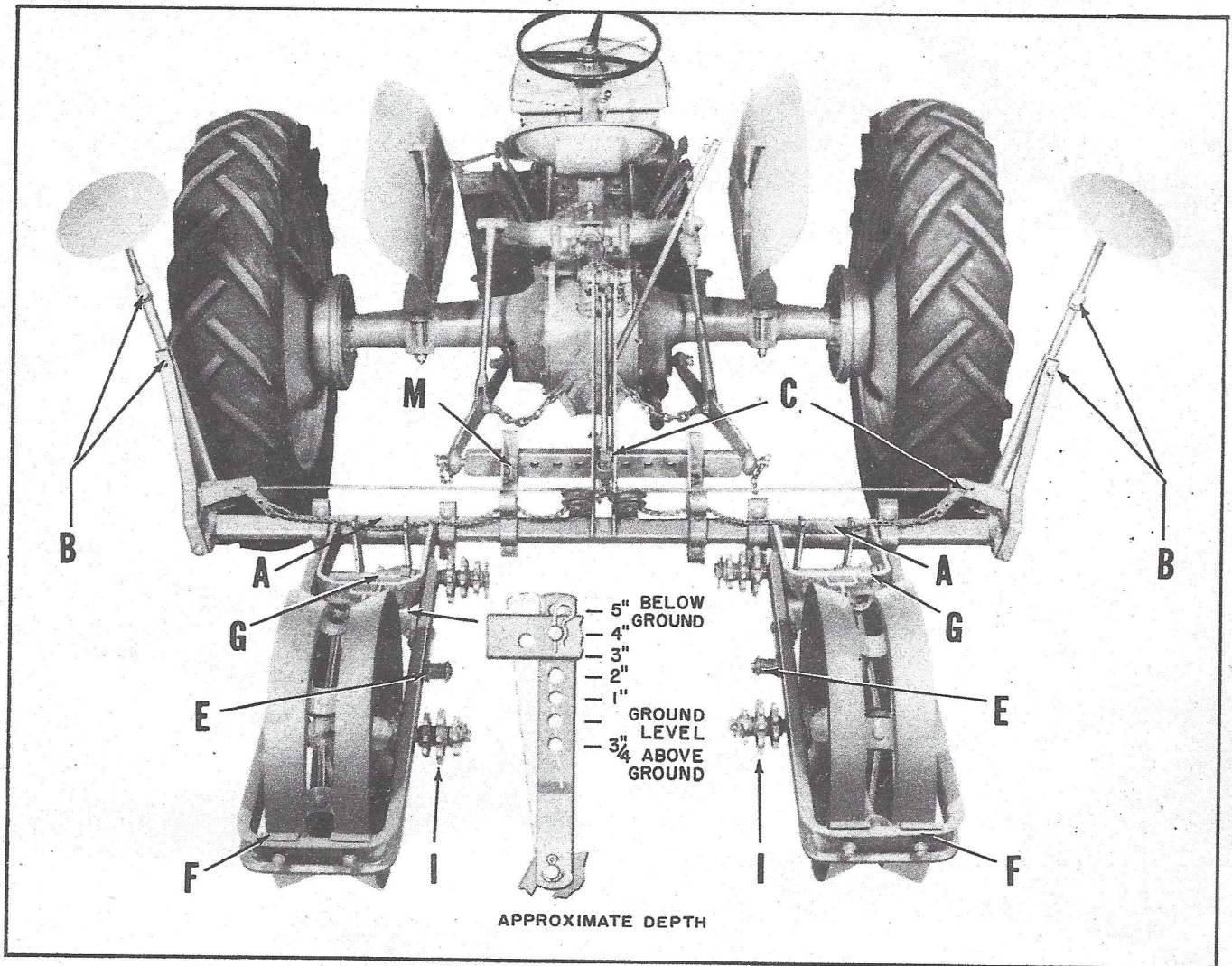

Fig. 2

widths, it will be necessary to measure additional 1" spacings on the square bar of the main frame.

(b) Disc Markers.

The spacings of the markers should be made to permit the operator to sight along the center of the hood of the tractor. To properly set the disc markers for the selected row spacing, the marker disc center shall be 1-1/2 times the row spacing from the nearest runner. For example,

a 40" row will require a 60" setting on the marker.

The telescopic extensions of the marker arms must be inserted a minimum of 4" to provide adequate support for the entire marker assembly.

(c) Marker Chains.

To adjust the marker chains, it is necessary that the planter be mounted on a tractor and the planter raised to the transport position. Place chain strap in upper

FERGUSON D-PO-A-20 DRILL PLANTER

hole of marker assembly for wide row spacing, and in lower hole for narrow row spacing. Remove all the slack from the chain by tightening wing nut on pickup arm. If all the slack cannot be removed or the chain is too tight, additional adjusting holes are provided in the chain strap. Raise and lower planter, tripping the markers, and check for proper latching when planter is raised.

(d) Depth of Planting.

Depth of planting is determined by the relationship of the bottom of the runners to the bottom of the press wheel.

A strap assembly with seven adjustment holes (See Insert Fig. 2) connects the heel of the runner with the press wheel frame assembly. Two holes are located in the frame clip to which the strap assembly may be attached. When placed in the forward hole, depths of planting can be obtained ranging from 3/4" above the ground to 5" below the surface of the ground, varying in 1" increments. When placed in the rearward slot, the intermediate increments of the above spacings can be obtained.

The actual depth of planting should be checked in the field and adjustments made

for desired depth to meet varying field conditions.

A 1-1/2" slot is located where the strap assembly is pinned to the boot to allow for the hitting of any obstructions, or for operating on extremely rough or uneven ground.

(e) Drive Chain.

Slack in the drive chains can be removed by the use of the idler. However, it may be necessary to add or remove links to accommodate the sprocket combination in use. The chains should not be excessively tightened by the idlers. Sufficient slack must be left in the chains to allow full flexibility of all links. This adjustment can easily be checked by spinning the press wheels while the planter is in the transport position.

(f) Press Wheel Scrapers.

The press wheel scrapers are fitted snug with the press wheel to give a clean, positive scraping action. No adjustment is necessary as the spring-loaded scrapers adjust themselves against the press wheel.

(g) Seating of Hopper.

To obtain the proper seating of the hopper to the planter unit and to insure a proper mesh with the drive pinion gear, ad-

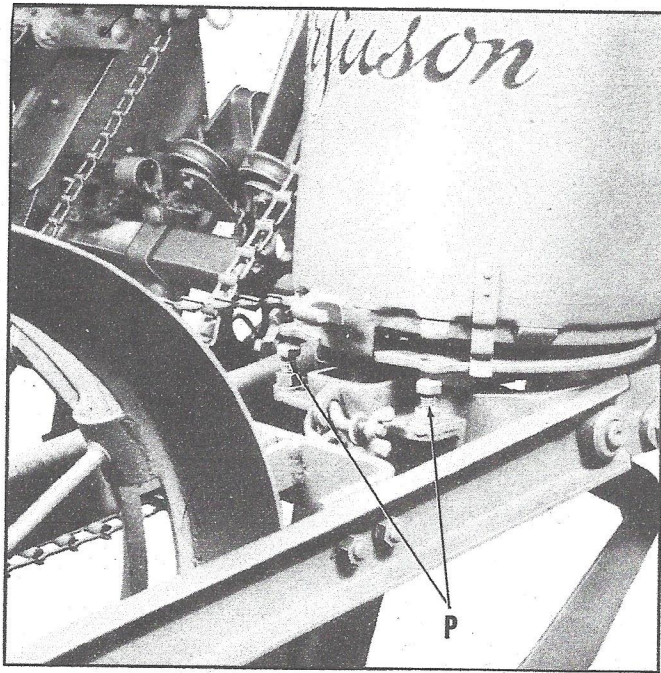

Fig. 3

just the two bolts P, Fig. 3. On planters after Serial No. 2000, these bolts must be readjusted when changing false plates. A check should be made on the pinion gear to make certain it is properly bolted in position on the pinion shaft. This pinion is secured to the shaft by a 1/4" x 1-1/2" bolt through the shaft and pinion. The pinion assemblies are always located on the R.H. side of the hopper drive shaft for both R.H. and L.H. planter units. It is important that these two gears mesh fully. An improper mesh will cause quick wear of gears and may result in breakage. Turn hopper shaft by hand while adjusting gear mesh to get feel of proper mesh with absence of binding and backlash.

(h) Tractor Wheel Spacing.

For the most commonly used row spacings, the following tractor wheel settings are suggested.

For 32" Rows - Space Wheels at 64"

For 34" Rows - Space Wheels at 68"

For 36" Rows - Space Wheels at 72"

For 38" Rows - Space Wheels at 76"

On these settings, it is possible to make the return trip in the same tractor wheel tracks. However, with other row spacings, it is necessary to use the disc markers. The wheel spacings may then be set at any desired width which will clear the planting row.

(i) Seed Spacing

The set of sprockets provided with the planter will provide seed spacings ranging from 1" to 34", depending on the number of cells in the seed plate. Various combinations can be made with these sprockets, according to the chart shown on the next page. As shown by this chart, output can also be controlled by the two gears on the hopper drive plate, which is driven by the pinion on the hopper drive shaft, Fig. 5. This hopper drive pinion can be located to drive either the inner or outer hopper gear by locating in the proper hole on the hopper drive shaft.

SEED SPACING

This Chart is a Guide - Check Actual Spacing in the Field

USE PROPER SEED PLATE

LARGE DRIVE GEAR UNDER HOPPER												
SEED SPACING - INCHES	7	9	10	12	14	16	18	20	22	25	29	34
SEED PLATE NO. OF CELLS	24	24	24	24	24	24	24	24	24	24	24	24
PRESS WHEEL SPROCKET *	11	9	11	10	9	8	7	10	9	8	7	6
SEED HOPPER SPROCKET *	7	7	10	11	11	11	11	18	18	18	18	18
SMALL DRIVE GEAR UNDER HOPPER												
(Limit Planting Speed From 2 M.P.H. for 3/4" Spacing to 3.5 M.P.H. for 9" Spacing)												
SEED SPACING - INCHES	1	2	2½	3½	1½	2½	3	4	4	5	7	9
SEED PLATE NO. OF CELLS	48	48	48	48	36	36	36	36	24	24	24	24
PRESS WHEEL SPROCKET *	18	11	11	9	18	10	11	7	11	11	9	7
SEED HOPPER SPROCKET *	6	7	10	11	8	7	10	8	7	10	11	11

EXAMPLE - Desired Seed Spacing 16" With a 24 Cell Plate Planter Sprockets Are: Press Wheel 8, Seed Hopper 11

* - Sprocket Numbers Refer to Number of Teeth in Sprocket

Fig. 4

SEED PLATES AND FALSE PLATES

Three seed plates which have the most general use, the D-PO-1863, D-PO-1864 and D-PO-1865, will be supplied with the planter as standard equipment (Page 21). One false plate, D-PO-1828, which will fit all three standard seed plates, will also be supplied. Many variations of seed plates are available. For selection of proper seed plate and false plate, the drawings on Page 21 are to actual size. Place the largest of the seeds over this drawing, which will give a check as to size of seed plate and false plate required for the particular planting op-

eration. It is extremely important that every different type and grade of seed be checked for fit with the actual cell on the seed plate and that only uniformly graded seed be used. Improper matching of seeds to seed cells is the cause of most planting difficulties.

The false plates are made of cast iron. The two false plates are designed differently on each side, so that they may be turned over if necessary to match the seed plate being used.

The stamping on the false plates describes which side of the false plate should

FERGUSON D-PO-A-20 DRILL PLANTER

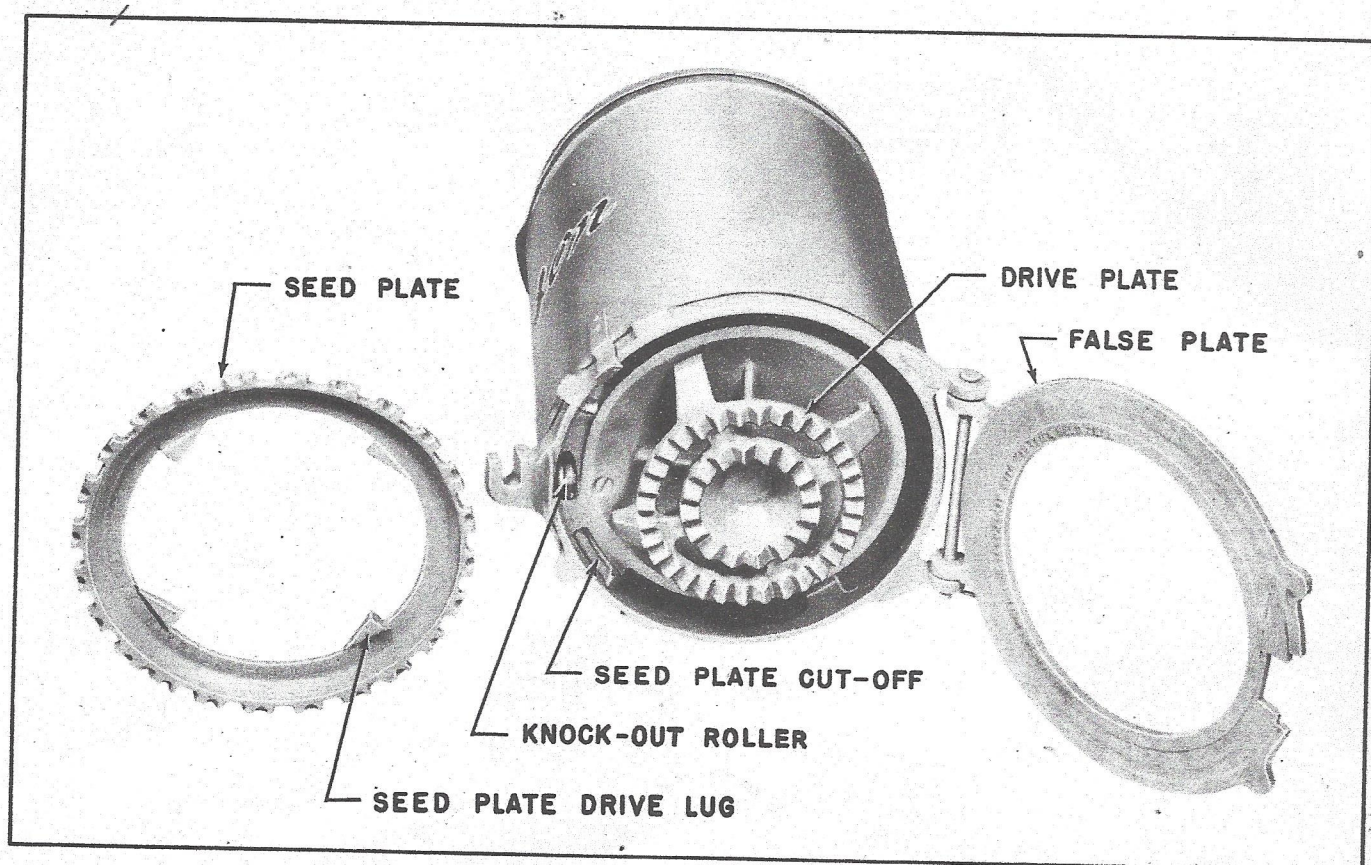

Fig. 5

be facing the selected seed plate. Refer to seed plate selection chart to determine the thickness of each seed plate. A check of both false plates should be made before operating to determine if they are installed with the correct side facing the seed plate.

HOPPER OPERATION

The hopper drive plate, Fig. 5, is rotated through the action of the drive pinion. The drive plate arms seat against the seed plate drive lugs, Fig. 5, causing the seed plate to rotate. It is not necessary for all four drive lugs to come in contact with the drive plate at the same time.

As the seed plate revolves, the cells pass under the seed plate cutoff, which

acts under spring pressure. It pushes the extra kernels back away from the cells and, at the same time, presses the kernel into the cell.

As the plate revolves to where the cell is over the seed tube, a knock-out roller under spring pressure comes in contact with the kernel, knocking it through the cell into the seed tube, where it falls directly into the soil. It is important that the knock-out roller be assembled with its flat face toward the center of the seed hopper.

The spring-loaded knock-out and seed plate cutoff must be checked periodically for wear and correct action, to prevent any clogging action and resultant skipping during planting operation.

FERGUSON D-PO-A-20 DRILL PLANTER

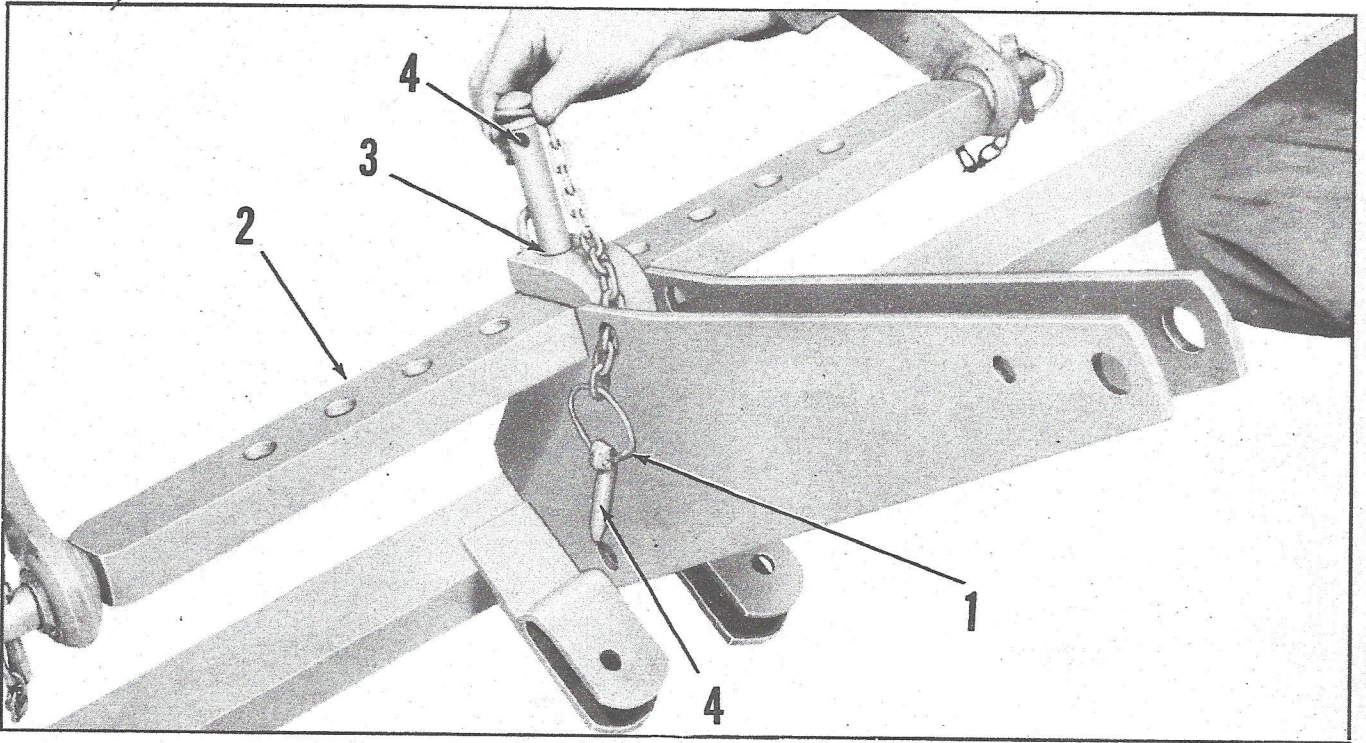

Fig. 7

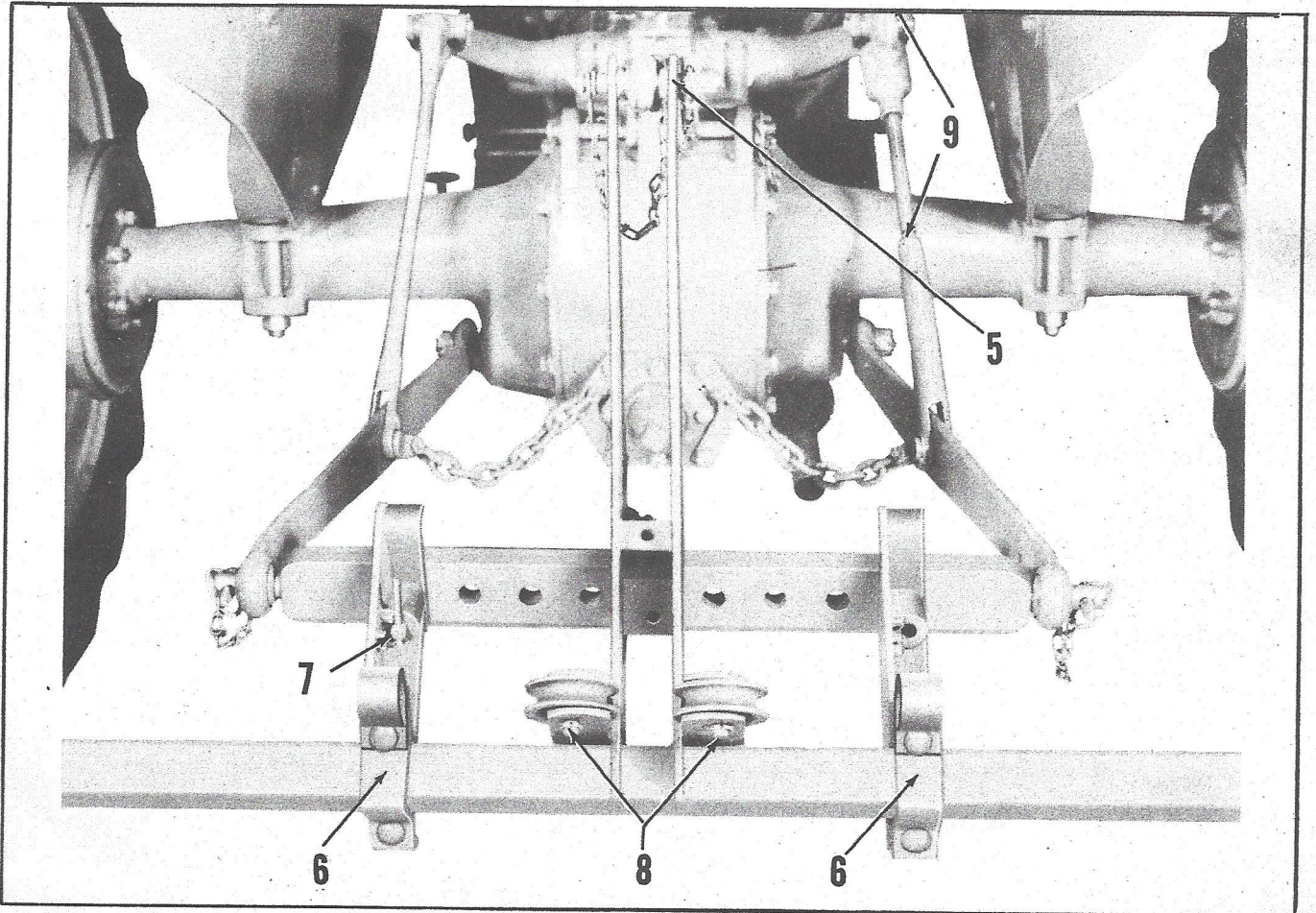

Fig. 8

FERGUSON D-PO-A-20 DRILL PLANTER

5. Attach tractor top link to main frame assembly.
6. Clamp drawbar stop assemblies to main frame, using $5/8''$ x $2''$ bolts, with bolt heads to rear. Line up stop pin with outside hole on drawbar. Clamp chain guides behind bolt head as shown.
7. Lock stop pin in outside hole on drawbar. This stop pin can be installed on either side.
8. Install marker chain pulleys, using a $1/2''$ x $1-3/4''$ clevis pin and cotter pin.
9. Place lower links in level position by turning levelling lever on tractor hydraulic lift rod.
10. Insert pivotbar through main frame.
11. Install marker trip handle on pivot bar, using $5/16''$ x $1-3/8''$ clevis pin and cotter pin.
12. Pin marker trip handle to main frame, using $3/8''$ x $2-7/8''$ clevis pin and cotter pin.
13. Screw latch rods into pivot bar. Both sides must be threaded an equal distance for even tripping.
14. Position L.H. and R.H. planter units to main frame, aligning with row spacing notches on main frame. The center notch on square bar is for 40'' rows. Clamp with $5/8''$ x $2-1/2''$ bolts at points R, Fig. 9. Bolt heads must be to rear.
15. Install the 7, 8, and 9 tooth sprockets on the L.H. and R.H. pinion shafts.

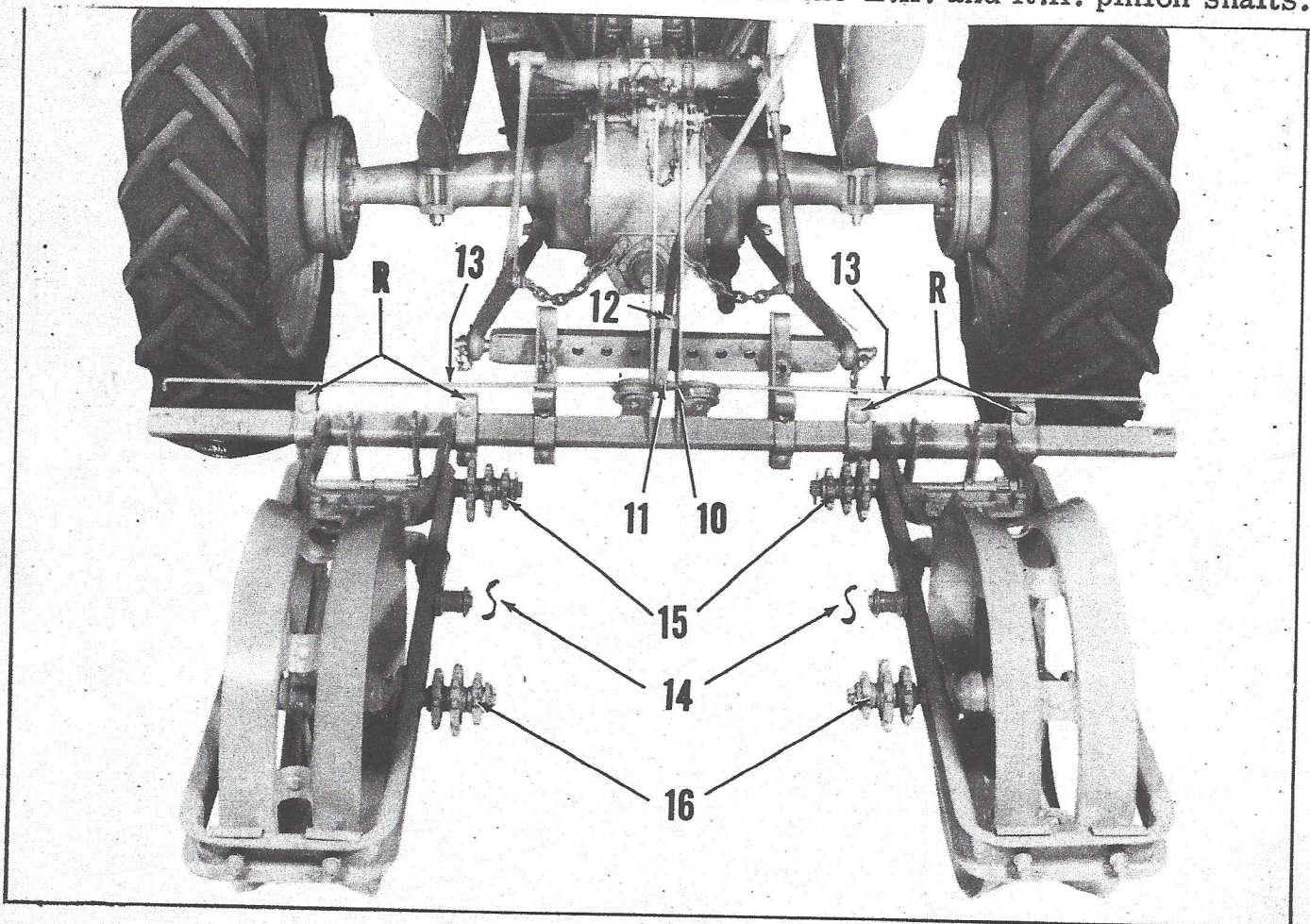

Fig. 9

FERGUSON D-PO-A-20 DRILL PLANTER

The part number and number of teeth is stamped on all sprockets. Retain sprockets with a cotter hair pin.

16. Install the 10, 11, and 18 tooth sprockets on the L.H. and R.H. press wheel shafts. Retain sprockets with a cotter hair pin.

17. Position R.H. and L.H. marker bracket assemblies flush with the ends of the main frame bar. Clamp into position with $7/16'' \times 2-3/8''$ bolts.

18. Install marker latch to marker bracket assembly with $1/2'' \times 1''$ clevis and cotter pin.

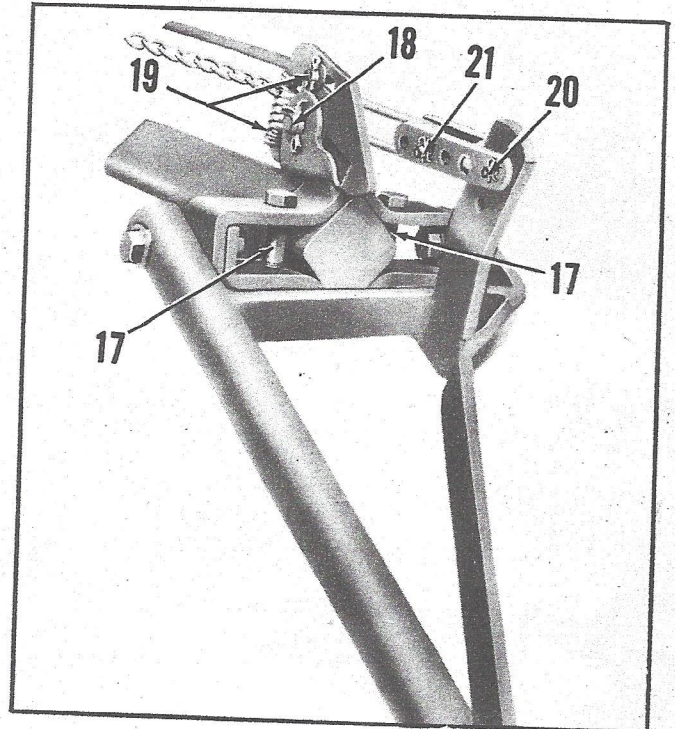

Fig. 10

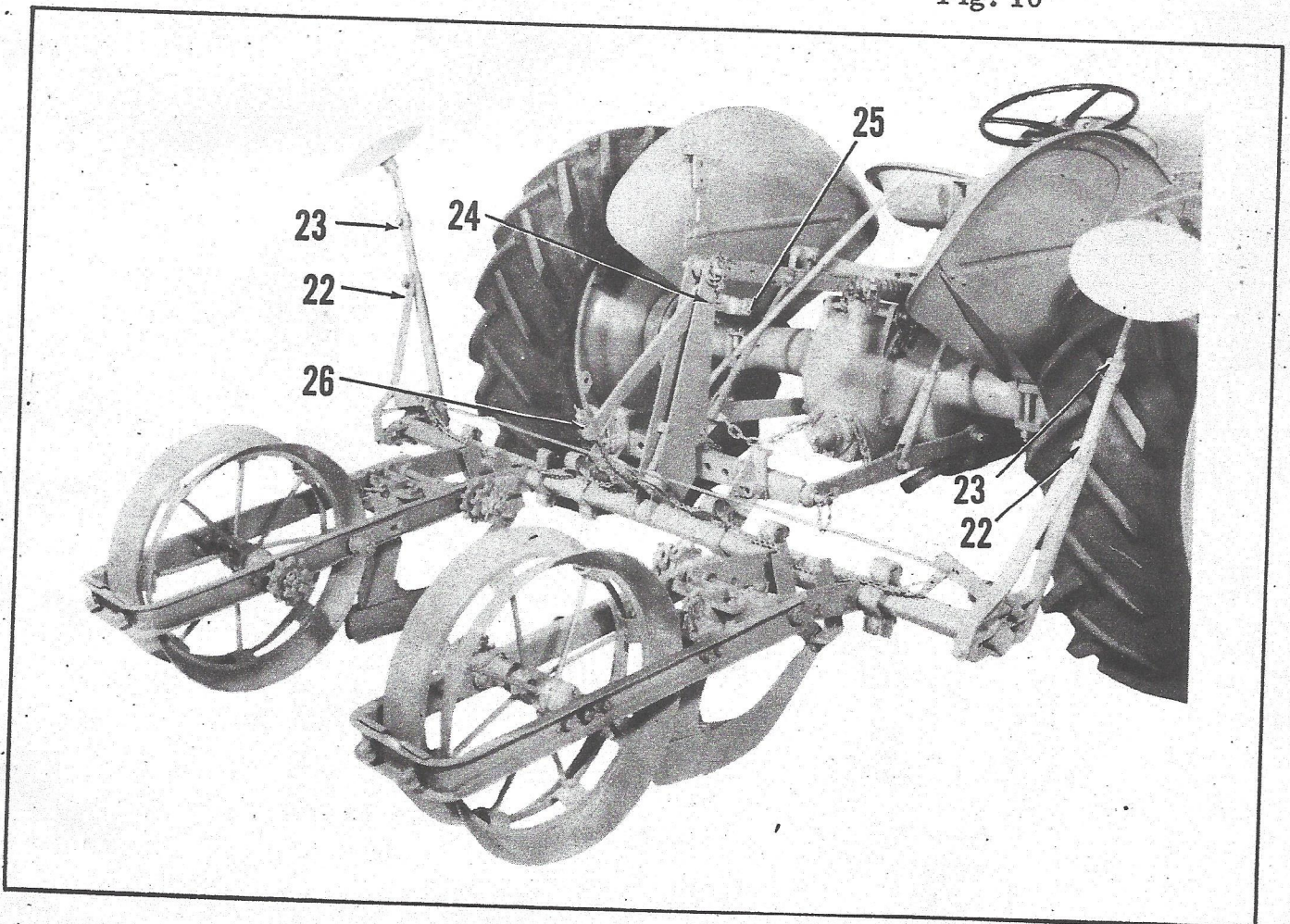

Fig. 11

FERGUSON D-PO-A-20 DRILL PLANTER

19. Install marker latch spring over hook on marker bracket clamp. Connect latch rod to marker latch with washer and cotter pin.

20. Place marker adjusting strap assembly in upper hole for wide row spacing, and in lower hole for narrow row spacing.

21. Connect marker chain to adjusting strap, using $5/16'' \times 7/8''$ clevis pin and hair pin.

22. Insert marker telescoping tube assembly into marker bracket assembly a minimum of 4". Lock in position with

$7/16'' \times 1''$ hex head bolt. See adjustments for correct setting to correspond with row spacing.

23. Insert disc marker extension into telescoping tube a minimum of 4". Lock in position with $7/16'' \times 1/2''$ hex head bolt.

24. Bolt marker pickup arm in main frame with $3/4'' \times 1-3/4''$ spacer and $7/16'' \times 2-3/4''$ bolt.

25. Insert marker chains in eye of pickup eyebolt. Slide eyebolt through eye of pickup arm. Install spring, spring retaining washer and wing nut. Tighten

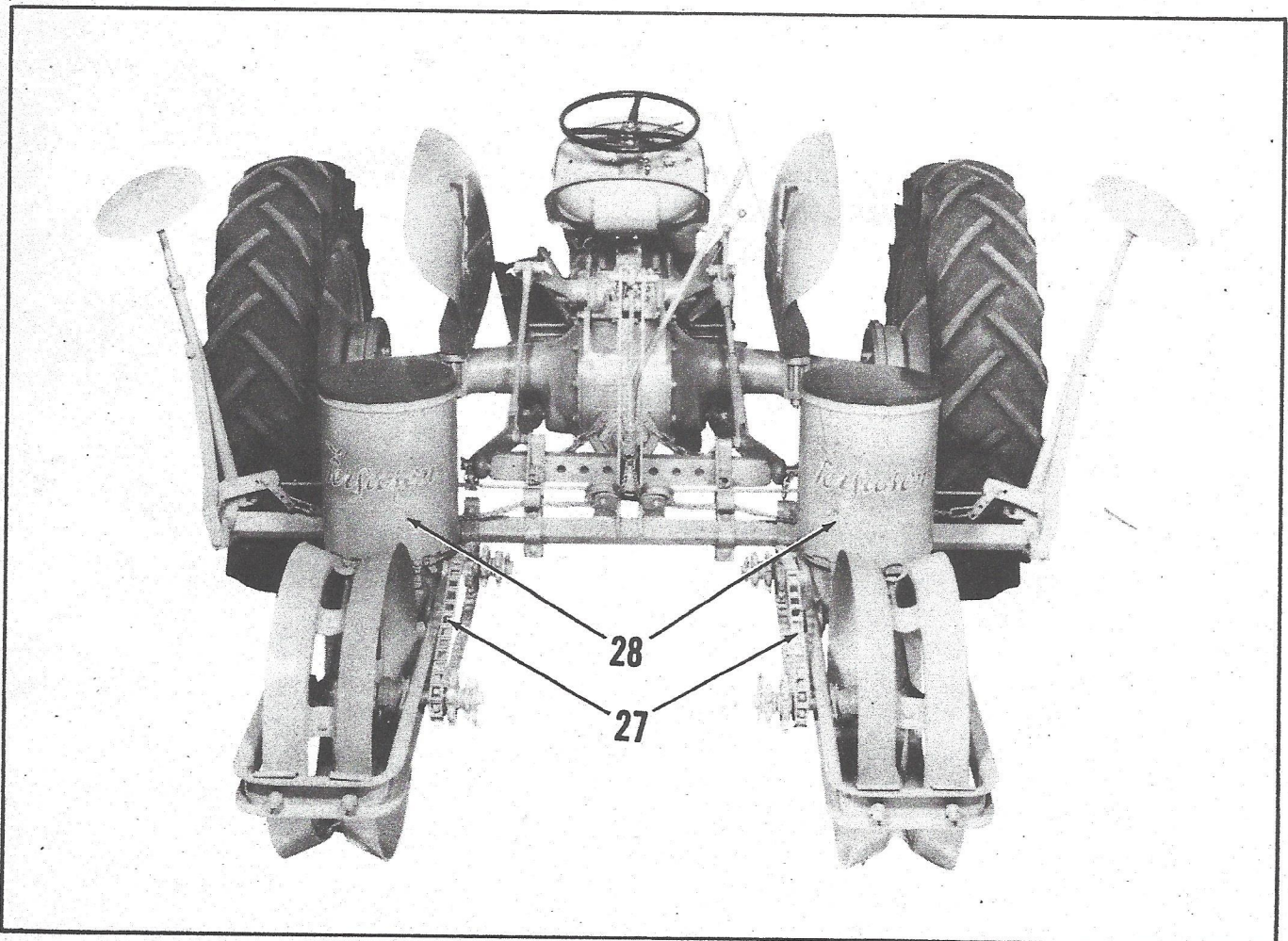

Fig. 12

A-RO-B-60 FERTILIZER ATTACHMENT

wing nut until correct lifting action of markers is observed. (See Adjustments)

26. Install planter chains on L.H. and R.H. planter unit sprockets. Chain links should be assembled, so small open end of link is facing outward and forward in direction of chain travel.

27. Place hoppers in position, making certain the proper mesh is obtained between drive plate gears and pinion gears. (See Adjustments)

28. Tighten all bolts and lubricate as directed in lubrication instructions.

ACCESSORIES

A-RO-B-60 FERTILIZER ATTACHMENT

The Fertilizer Attachment A-RO-B-60 for the Drill Planter consists of two individual units, which are easily attached to the planter. It is capable of effectively distributing both damp and dry fertilizer at a rate ranging from 50 lbs. to 575 lbs. per acre. It can satisfactorily deposit fertilizer in the soil at an adjustable depth and predetermined distance from the seed which is being planted by the planter.

LUBRICATION

Four pressure fittings are located on the cast iron bearings of the metering shaft T, Fig. 16, one on each side of both units. These bearings shall be lubricated with a chassis lubricant every four hours of operation. A few drops of

oil should be placed on the chain idler roller during each greasing operation.

ADJUSTMENTS

1. Row Spacing.

The fertilizer attachment is bolted to the planter units and moves to the right or left as the planter row adjustment is being made.

2. Dry Fertilizer Adjustment.

When attempting to apply extremely dry, free-running fertilizer, the metering plate K, Fig. 13, should be moved rearwardly to the extent of the slotted hole to decrease the flow of fertilizer. A field check of output must be made after this adjustment.

A-RO-B-60 FERTILIZER ATTACHMENT

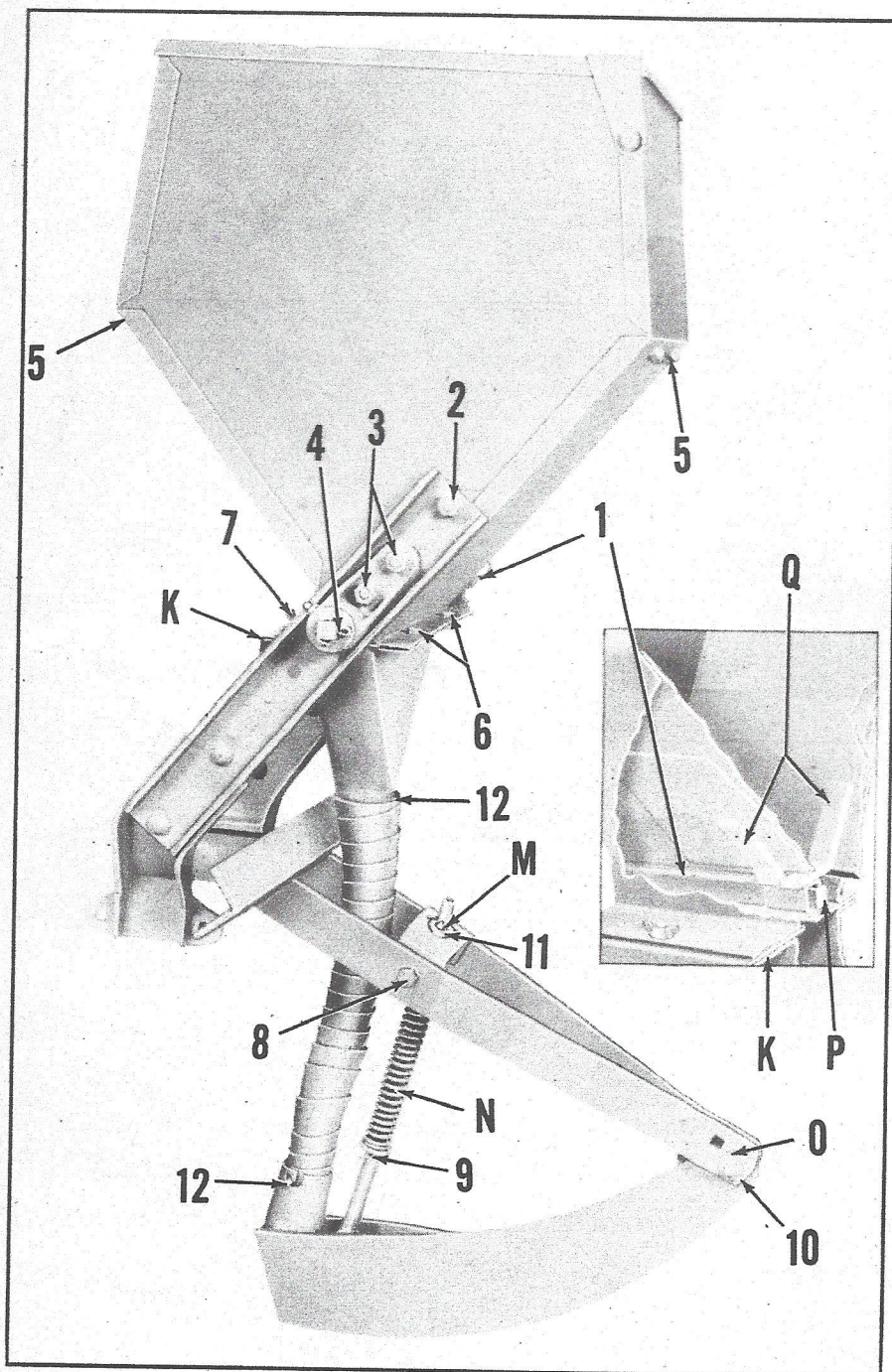

Fig. 13

3. Side Adjustment of Runners.

Provision has been made to deposit the fertilizer at various distances from the side of the seed row. To position

fertilizer runners to side, loosen the clamps L, Fig. 16, slide the runner bracket on the square bar to the desired position.

4. Depth of Application.

Depth of application is controlled by raising or lowering the depth rod M, Fig. 13, until the correct depth is obtained. Due to variable soil and seedbed conditions, this adjustment must be checked in the field. The holes on the depth rod are spaced at $3/4$ " intervals and the depth of fertilizer placement can be changed by varying the location of the cotter pin and washer. A spring N, Fig. 13, is placed under the depth rod brace to permit the runner to float upward and return to the specified depth, if an obstruction

is hit or when operating in extremely rough ground. The compression on the spring may be varied by relocating the washer and cotter pin located under the spring.

A-RO-B-60 FERTILIZER ATTACHMENT

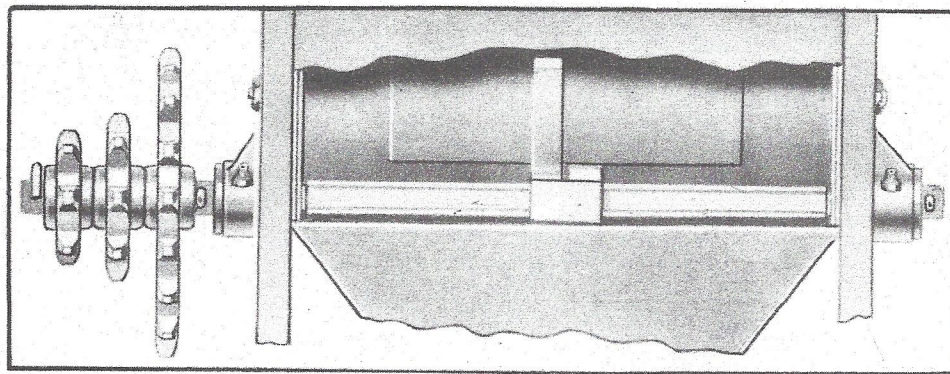

Fig. 14

5. Vertical Angle of Runner.

To provide a vertical adjustment of the front of the runner, two holes are located in the runner bracket assembly, O, Fig. 13, in which the runner may be bolted.

6. Rate of Output.

Rate of output is controlled by arrangement of sprocket combinations. Refer to chart on next page. A similar chart is located under the fertilizer lid.

7. Idler Sprocket.

Slack in the fertilizer drive chain can be removed by adjustment of the idler. Do not tighten the chain to the extent that flexibility of the chain is lost. When the planter is in raised position, it should be just possible to spin the press wheel by hand.

FERTILIZER HOPPER

Each fertilizer hopper will hold approximately 100 lbs. of commercial fertilizer. The fertilizer fluted tube feed shaft and the metering plate are made of stainless steel, and the inside of the

hopper is coated with Ferguson Protective Coating to resist rust and corrosion. When installing a new fluted tube on the metering shaft, the metering shaft should be coated with cup or axle grease.

As the press wheel of the planter rotates, the fertilizer sprockets drive the feeder shaft P, Fig. 13. Both sides of the hopper have agitators with arms Q, Fig. 13, riding on a raised cam at the center of the square shaft. As the shaft rotates, a vibration is set up in the agitator plates. This prevents the fertilizer from "bridging" and piling up on the sides of the hoppers, thus assuring free and even feeding to the fluted tube feed shaft.

The fertilizer is forced under the rotating fluted shaft to the opening in the rear of the hopper, where it falls through the funnel and flexible tubing to be deposited in the soil.

MAINTENANCE OF FERTILIZER HOPPERS

FOR EFFICIENT OPERATION AND MAINTENANCE OF FERTILIZER HOPPERS, THEY MUST BE KEPT CLEAN AT ALL TIMES WHEN NOT IN USE. Commercial fertilizers are very acidic, and will rust and corrode metal in a very short time. To properly care for your fertilizer attachment, the following steps should be taken:

A-RO-B-60 FERTILIZER ATTACHMENT

1. Do not allow fertilizer to remain in the box for more than 48 hours between planting operations.
2. After planting is completed, remove all fertilizer from box, remove agitators and use a wire brush to clean hoppers and shafts.
3. Wash all parts with hot water until

free from fertilizer.

4. Coat all surfaces with light crank-case oil.

5. For longer life, the boxes should be repainted with primer and Ferguson Protective Coating at the close of each season's operation. These are available at your nearest Ferguson Dealer.

FERTILIZER APPLICATION RATE

This Chart is a Guide - Actual Rate Should be Checked in the Field

PLANTER SPROCKETS

Determine From Seed Spacing Chart Before Selecting Fert. Sprockets

		PLANTER SPROCKETS																			
		Damp ↓ Dry	PRESS WHEEL	6	7	8	9	10	7	8	9	7	10	11	9	10	11	18	18		
		SEED HOPPER	18	18	18	18	18	11	11	11	8	11	10	7	7	7	8	6			
FERTILIZER RATE - LBS. PER ACRE	Rates Shown are Based on 40 Inch Row Spacing	50 DRIVER (Lower)	7	6	9	7	7	6													
		100 (Upper) DRIVEN	12	12	11	18	18	18													
		75 DRIVER	10	9	6	6	6	8	7	6	6										
		125 DRIVEN	12	12	10	11	12	18	18	18	18										
		100 DRIVER	10	11	11	6	9	6	7	6	6	8	7	6							
		175 DRIVEN	8	9	12	7	12	9	12	12	18	18	18								
		125 DRIVER	9	7	7	11	9	7	6	10	9	9	7	6	6						
		200 DRIVEN	7	6	7	12	11	10	10	18	18	18	18	18	18						
		150 DRIVER	12	12	9	8	7	8	7	7	6	8	9	8	7	7					
		250 DRIVEN	7	8	7	7	7	9	9	10	9	12	18	18	18						
		175 DRIVER	18	12	9	8	11	10	7	8	9	9	8	6	8	8					
		275 DRIVEN	9	7	6	6	9	9	7	10	12	12	12	11	18	18					
		200 DRIVER	18	12	12	12	9	12	7	7	6	6	8	7	6	9	6				
		325 DRIVEN	8	6	7	8	7	10	7	7	7	7	12	12	11	18	18				
		225 DRIVER	18	12	11	11	12	10	10	7	10	8	9	8	7	10	7				
		350 DRIVEN	8	6	6	7	8	8	9	7	11	9	12	12	12	18	18				
		250 DRIVER	18	18	12	11	11	12	12	8	12	7	6	8	8	7	7				
		400 DRIVEN	7	8	6	6	7	8	9	7	11	7	7	11	12	12	18				
		275 DRIVER	18	18	12	11	12	18	12	7	12	7	6	6	6	6	8	6			
		425 DRIVEN	7	7	6	6	7	12	9	6	11	7	7	8	9	10	18	18			
		300 DRIVER		18	18	12	12	10	9	8	11	12	7	10	6	6	6	7			
		450 DRIVEN		6	8	6	6	6	6	6	9	10	7	12	8	9	12	18			
		325 DRIVER		18	18	18	12	12	12	18	9	8	7	8	6	7	6	8			
		525 DRIVEN		6	7	8	6	6	7	12	7	6	6	8	7	9	11	18			
350 DRIVER			18	18	18	12	12	10	9	9	7	12	11	10	6	8					
550 DRIVEN			6	7	8	6	6	6	6	6	6	10	12	12	10	18					
375 DRIVER				18	18	18	12	12	11	9	12	11	11	8	6	9					
575 DRIVEN				6	7	8	6	7	7	6	9	10	12	9	10	18					

FERTILIZER SPROCKETS

Sprocket Numbers Refer to Number of Teeth in Sprockets

EXAMPLE - Planter Sprockets are Press Wheel 8 Teeth - Seed Hopper 11 Teeth. The Desired Rate of Fertilizer Application is 225 Lbs. Per Acre of Damp Fertilizer. The Proper Sprockets Should Be; Driver 10 Teeth - Driven 9 Teeth.

Fig. 15

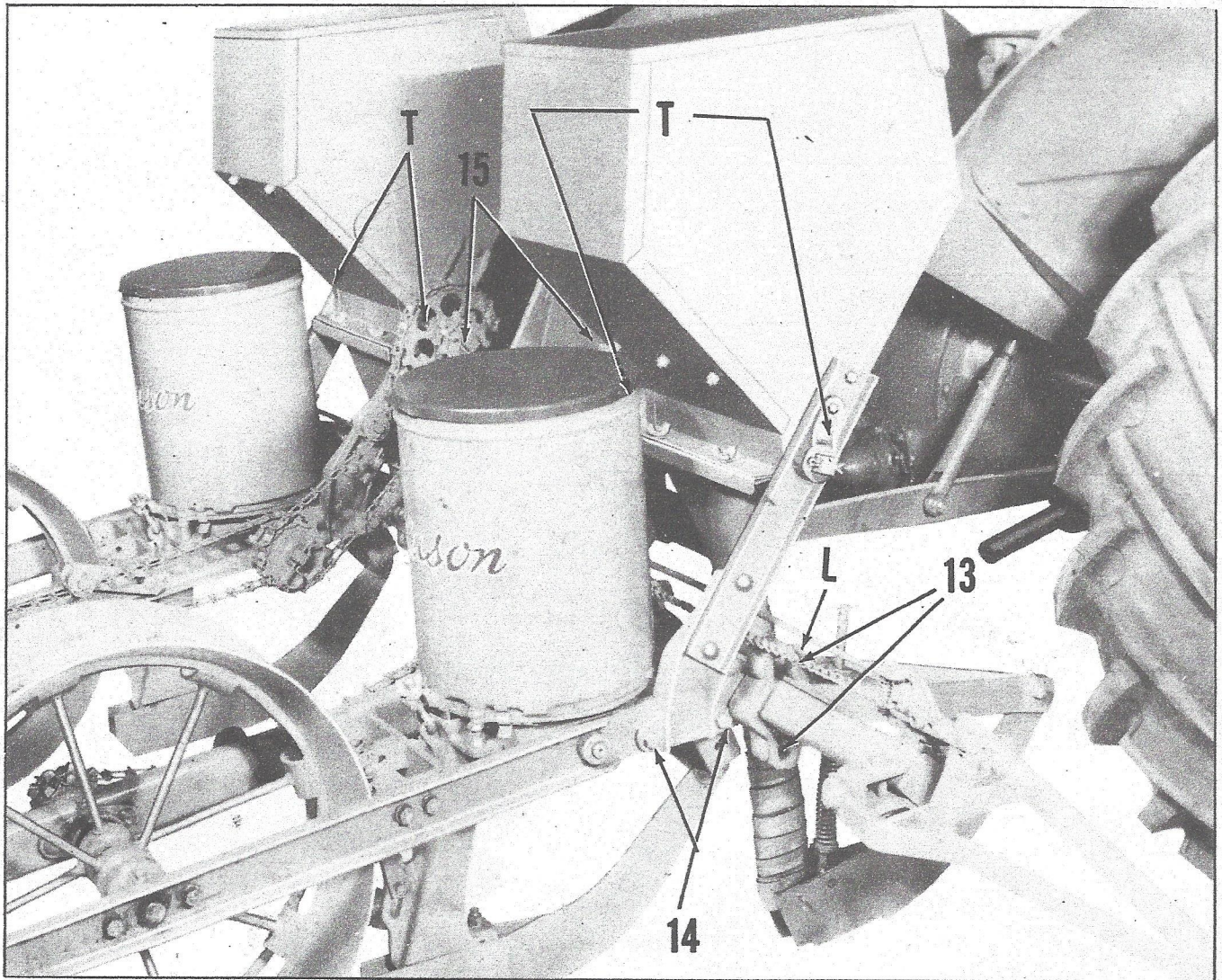

Fig. 16

FERTILIZER ATTACHMENT ASSEMBLY INSTRUCTIONS

The Fertilizer Attachment is shipped completely disassembled. The following steps should be followed in the assembly operation. The numbers on the illustrations correspond with the step number in the assembly instructions.

1. Remove all parts and hardware from the box. Coat metering shaft with

cup or axle grease prior to assembling fluted tubes, to protect shaft from corrosion when in contact with fertilizer. Place cast iron bearing, hopper bearing bracket, and hopper bracket assembly on metering shaft. Slide small end of shaft through drive side of hopper. Both hoppers are driven from the inside of the planter units. Position thrust washer,

A-RO-B-60 FERTILIZER ATTACHMENT

metering shaft fluted tube, agitator cam, second metering shaft fluted tube and second thrust washer in the order named, installing from inside the hopper. (See Fig. 14). Slide metering shaft through opposite end of hopper.

2. Bolt L.H. and R.H. hopper bracket assembly to hopper with $7/16''$ x $7/8''$ bolts.

3. Bolt L.H. and R.H. hopper bearing brackets to hopper bracket assembly and hopper, using $7/16''$ x $1-1/8''$ bolts. To differentiate L.H. from R.H., the grease fitting is to be installed in the upright position.

4. Lock bearing into position with cotter pin.

5. Install front and rear agitator assemblies, bolting to hopper with $5/16''$ x $5/8''$ round head screws, flat washer and lockwasher. The front agitator assembly has the small lip on the under side.

6. Bolt front of hopper funnel assembly to hopper, placing metering plate K, Fig. 13, between both units. Use $5/16''$ x $5/8''$ bolts.

7. Secure rear of hopper funnel assembly and metering plate to hopper, using a $5/16''$ x $5/8''$ bolt and wing nuts.

8. Bolt depth rod brace to runner bracket assembly with $7/16''$ x $1-1/4''$ bolts.

9. Place cotter pin, retainer and spring in position on rod. See Adjustments for

proper location of cotter pin.

10. Place runner rod through depth rod brace. Secure runner to runner bracket assembly, placing spacer between runner bracket plates. Bolt with $7/16''$ x $1-1/4''$ bolts.

11. Lock rod to depth rod brace with washer and cotter pin, locating in selected hole on rod to give correct runner depth setting. (See Adjustments)

12. Clamp flexible tube assembly to hopper funnel assembly and heel of runner.

13. Clamp runners of fertilizer attachment to square bar of main frame of planter, using the special clamp supplied with the fertilizer attachment. Use the same bolts that are used on the planter.

14. Bolt bracket assembly to planter, using $7/16''$ x $1-1/2''$ bolts.

15. Install sprockets, locking in position with cotter pin on inside and hair pin on outside of shaft. There is a 6-, 7- and 12-tooth sprocket supplied with each fertilizer unit. All fertilizer attachment sprockets are interchangeable with the planter sprockets. Planter and fertilizer attachment sprocket drive combinations are shown on the planting and fertilizing charts supplied with the planter.

16. Lubricate as instructed. Raise planter and turn press wheels. Check fertilizer attachment for correct operation of all parts.

D-PO-A-72 PRESS WHEEL BAND ATTACHMENT

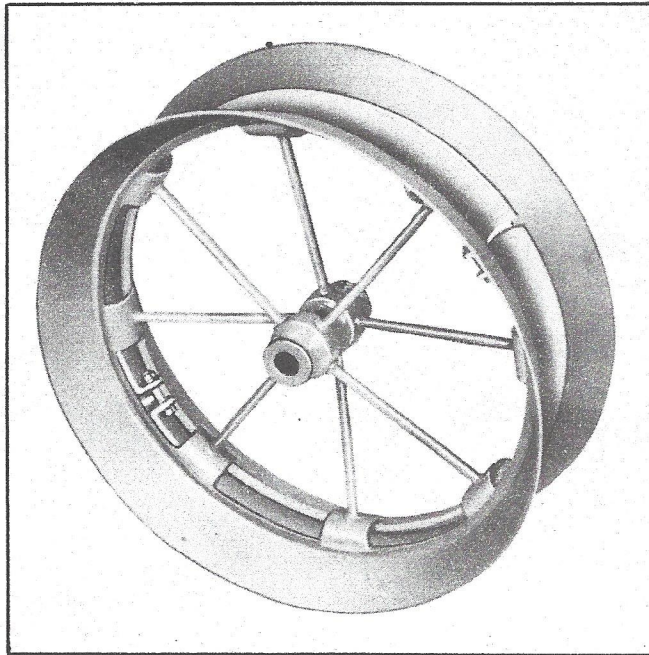

PRESS WHEEL BAND ATTACHMENT

When operating under extremely fine and loose soil conditions, a special press wheel band attachment, D-PO-A-72, is available from your Ferguson Dealer. Fig. 17. It may be installed over the press wheel to permit more effective packing of seed.

To install, place both halves together over press wheel and clamp together, using 5/16" x 1-3/8" bolts.

Fig. 17

SEED PLATE AND FALSE PLATE CHART

Seed Plate Number	No. of Cells	False Plate	Cell Dimensions		Full Size Thickness	Kind of Seed
			Length	Width		
D-PO-1830	24	D-PO-A1829	$\frac{1}{2}$	$\frac{7}{32}$	3/16	Extra Small Round Corn, Popcorn Small White Beans, Navy Beans (N.Y.), White Navy Beans
D-PO-1831	24	D-PO-A1828	$\frac{17}{32}$	$\frac{1}{4}$	5/16	Small Round Corn
D-PO-1832	24	D-PO-A1828	$\frac{19}{32}$	$\frac{9}{32}$	5/16	Medium Round Corn, Large Navy Beans, Valentine Green Pod Beans, Cranberry Beans, Golden Wax Beans, Pinto Beans
D-PO-1833	24	D-PO-A1828	$\frac{5}{8}$	$\frac{9}{32}$	5/16	Large Round Corn
D-PO-1834	24	D-PO-A1828	$\frac{5}{8}$	$\frac{5}{16}$	5/16	Large Round Corn, Romanie Beans, Bush Beans
D-PO-1840	24	D-PO-A1828	$\frac{15}{32}$	$\frac{7}{32}$	5/16	Small Thick Corn

SEED PLATE AND FALSE PLATE CHART

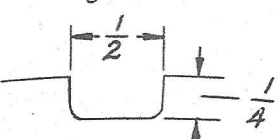
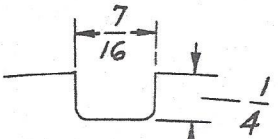
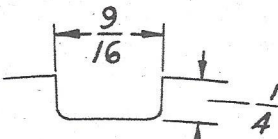
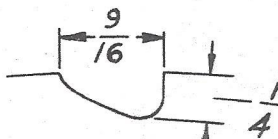
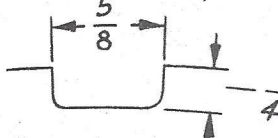
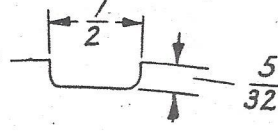
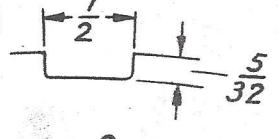
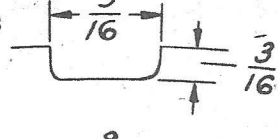
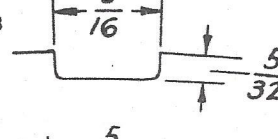
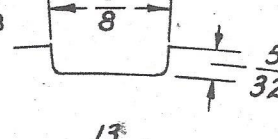
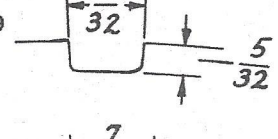
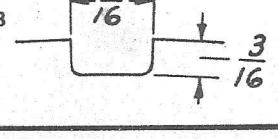
Seed Plate Number	No. of Cells	False Plate	Cell Dimensions Length Width	Full Size Thickness	Kind of Seed
D-PO-1841	24	D-PO-A1828		5/16	Large Thick Corn, Medium Argentine Corn, Great Northern Beans
D-PO-1842	24	D-PO-A1828		5/16	Medium Thick Corn, Large Sweet Corn, Baby Lima Beans
D-PO-1843 ✓	24	D-PO-A1828		5/16	Extra Large Thick Corn
D-PO-1850	24	D-PO-A1829		5/32	Extra Small Thin Corn
D-PO-1851	24	D-PO-A1829		5/32	Small Thin Corn, Medium Country Gentlemen Sweet Corn
D-PO-1852	24	D-PO-A1829		1/4	Extra Small Narrow Corn (Thin Cell)
D-PO-1853	24	D-PO-A1828		5/16	Extra Small Narrow Corn, Late Blend Silo Bred-Differs From D-PO-1863 By Large Lead-In Angle: Better Suited for Above Seed
D-PO-1854	24	D-PO-A1828		5/16	Small Slender Corn, Common Small Corn, Great Northern Beans-Differs From D-PO-1864 By Large Lead-In Angle: Better Suited For Above Seed
D-PO-1855	24	D-PO-A1828		5/16	Medium Thin Corn, Small Slender Hybrid
D-PO-1856	24	D-PO-A1828		5/16	Large Thin Corn
D-PO-1860	24	D-PO-A1829		1/4	Extra, Extra, Small Flat Corn
D-PO-1861	24	D-PO-A1828		5/16	Small Flat Corn, Japanese Popcorn

SEED PLATE AND FALSE PLATE CHART

Seed Plate Number	No. of Cells	False Plate	Cell Dimensions - Full Size Length Width Thickness	Kind of Seed
D-PO-1862	24	D-PO-A1828		Extra Small Flat Corn, Small Sweet Corn
D-PO-1863	24	D-PO-A1828		Medium Flat Corn-Differs From D-PO-1853 By Small Lead-In Angle: Better Suited For Above Seed
D-PO-1864	24	D-PO-A1828		Large Flat Corn, Wax Beans-Differs From D-PO-1854 By Small Lead-In Angle: Better Suited For Above Seed
D-PO-1865	24	D-PO-A1828		Extra Large Flat Corn, White Southern Corn, Common Red Cob Corn, Kentucky Wonder Beans.
D-PO-1870	27	D-PO-A1828		Soybeans
D-PO-A1871	48	D-PO-A1829		Small Beans: Small White Beans Navy Beans (N.Y.), White Navy Beans
D-PO-A1872	36	D-PO-A1828		Medium Beans: Large Navy Beans, Great Northern Beans, Wax Beans
D-PO-A1873	36	D-PO-A1828		Large Beans: Red, White & Imperial Wax Kidney; Golden Wax; Stringless & Valentine Green Pod.
D-PO-A1874	36	D-PO-A1829		Kafir & Sorghum
D-PO-1876		D-PO-A1829	Blank Plate	5/32
D-PO-1877		D-PO-A1829	Blank Plate	3/16
D-PO-1878		D-PO-A1829	Blank Plate	1/4
D-PO-1879		D-PO-A1828	Blank Plate	5/16

CROSS SECTION THROUGH FALSE PLATE #1828

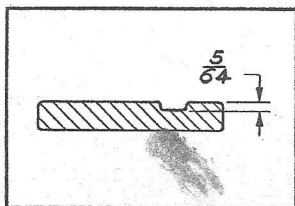

CROSS SECTION THROUGH FALSE PLATE #1829

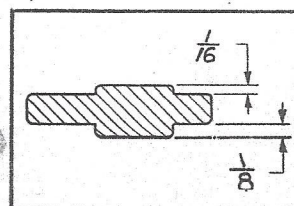

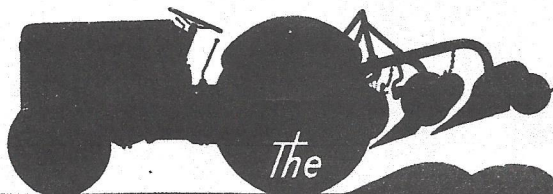

FERGUSON TRACTOR
and FERGUSON SYSTEM IMPLEMENTS

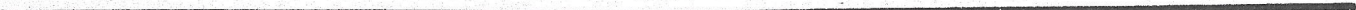

HARRY FERGUSON, INC.

IMPLEMENT

WARRANTY

For a period of ninety (90) days from the date of delivery of a new Ferguson Implement to the original purchaser thereof from a Ferguson Dealer, Harry Ferguson, Inc. warrants all such parts thereof (except tires) which, under normal use and service, shall appear to Harry Ferguson, Inc. to have been defective in workmanship or material.

This warranty is limited to shipment to the purchaser, without charge except for transportation costs, of the part or parts intended to replace those acknowledged by Harry Ferguson, Inc. to be defective.

If the purchaser uses or allows to be used on a Ferguson Implement parts not made or supplied by Harry Ferguson, Inc., or if any Ferguson Implement has been altered outside of its own factories or sources of supply, or if attachments have been used which were unsuited and harmful to the Ferguson Implement, then this warranty shall immediately become void. Harry Ferguson, Inc. does not undertake responsibility to any purchaser of a Ferguson Implement for any undertaking, representation, or warranty beyond those herein expressed.

Harry Ferguson, Inc. reserves the right to make changes in design or changes or improvements upon Ferguson Implements without any obligation upon it to install the same upon Implements theretofore manufactured.

See Your Ferguson Dealer for Information

— ON —

THE FERGUSON TRACTOR AND FERGUSON SYSTEM IMPLEMENTS

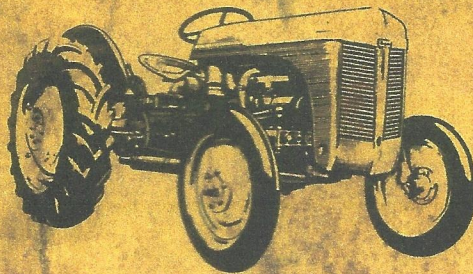

THE FERGUSON LINE

Of Implements Includes

Mold Board Plows	Manure Spreaders
Disc Plows	Manure Loaders
Two-way Plows	Corn Pickers
Spike Tooth Harrows	Corn Planters
Spring Tooth Harrows	Lister Planters
Single Disc Harrows	Grain Drills
Tandem Disc Harrows	Side Delivery Rakes
Bush and Bog Harrows	Rotary Hoes
Off-set Disc Harrows	Cordwood Saws
Spring Tine Cultivators	Rear Cranes
Rigid Tine Cultivators	Middle Busters
Lister Cultivators	Ridgers
Agricultural Mowers	Stalk Cutters
Heavy Duty Mowers	Four-row Weeders
Disc Terracers	Four-Wheel Wagons
Blade Terracers	Soil Scoops

Sub Soilers



FERGUSON TRACTOR
and FERGUSON SYSTEM IMPLEMENTS